

# DURAVALVE MODEL DM 350 BALL VALVE

## with DurAir II Pneumatic Actuator

### VALVE FEATURES

- Internal Entry Anti-Blowout Stem
- Adjustable Vee Style Stem Packing
- In-Line Maintainable
- Stainless Steel Cast Body and Ends
- Threaded to ANSI B2.1
- Meets WW-V-35 Design Specifications
- ISO 5211 Direct Mounting Pad

### ACTUATOR FEATURES

- ISO 5211 Mounting Pattern
- Aluminum Body
- Rack & Pinion Double Acting and Spring Return
- Low Friction Bearings and High Cycle Life

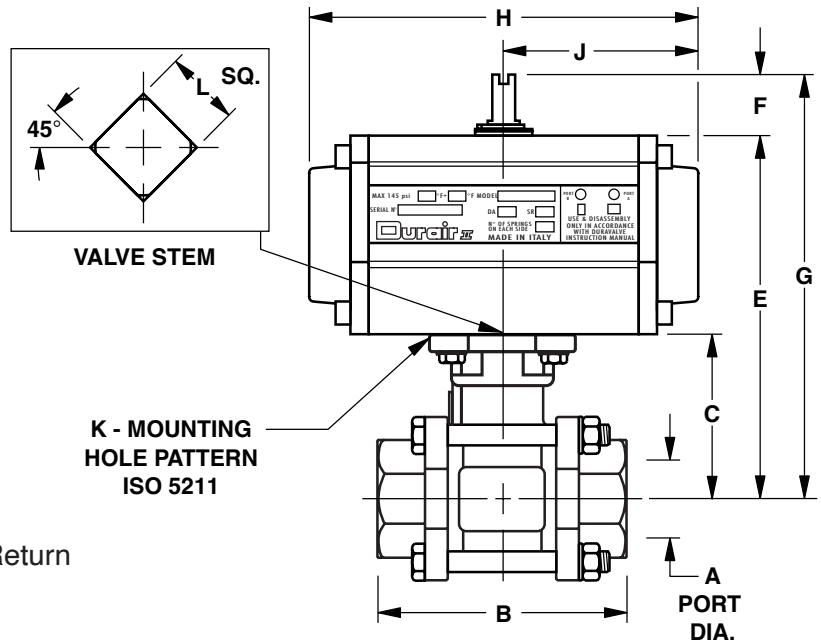

### DOUBLE ACTING (Dimensions in inches)

Valve Size	Assembly No w/Thread. Ends	Assembly No. w/SW Ends	Actuator Model No.	A	B	C	E	F	G	H	J	K	L
1/2	AS3102	NA	AP032	.59	2.96	1.50	3.42	.79	4.21	4.61	2.31	F03	.35
3/4	AS3103	NA	AP050	.79	3.15	1.85	4.52	.79	5.31	5.43	2.72	F03	.35
1	AS3104	NA	AP050	.98	3.54	2.36	4.86	.79	5.65	5.43	2.72	F04	.43
1-1/4	AS3105	NA	AP063	1.26	4.33	2.47	5.67	.79	6.46	6.12	3.06	F04	.43
1-1/2	AS3106	NA	AP063	1.50	4.72	3.11	6.99	.79	7.78	8.27	4.14	F07	.55
2	AS3107	NA	AP075	1.97	5.51	3.46	7.30	.79	8.09	8.27	4.14	F07	.55
2-1/2	AS3108	NA	AP085	2.52	7.28	4.29	9.20	.79	9.99	11.04	5.52	F10	.67
3	AS3109	NA	AP100	3.54	8.07	4.57	10.23	1.18	11.02	12.20	6.10	F10	.67

### SPRING RETURN (Dimensions in inches)

Valve Size	Assembly No w/Thread. Ends	Assembly No. w/SW Ends	Actuator Model No.	A	B	C	E	F	G	H	J	K	L
1/2	AS3112	NA	AP050	.59	2.96	1.50	4.28	.79	5.07	5.43	2.72	F03	.35
3/4	AS3113	NA	AP050	.79	3.15	1.85	5.16	.79	5.95	6.12	3.06	F04	.35
1	AS3114	NA	AP063	.98	3.54	2.36	5.50	.79	6.29	6.12	3.06	F04	.43
1-1/4	AS3115	NA	AP075	1.26	4.33	2.47	6.34	.79	7.13	8.27	4.14	F05	.43
1-1/2	AS3116	NA	AP075	1.50	4.72	3.11	7.38	.79	8.17	8.97	4.49	F07	.55
2	AS3117	NA	AP085	1.97	5.51	3.46	8.28	.79	9.07	11.04	5.52	F07	.55
2-1/2	AS3118	NA	AP115	2.52	7.28	4.29	9.88	1.18	11.06	12.20	6.10	F10	.67
3	AS3119	NA	AP125	3.54	8.07	4.57	11.52	1.18	12.31	15.35	7.68	F10	.67

