

# DURAVALVE MODEL DM 350 BALL VALVE

## with Electric Actuator

### VALVE FEATURES

- Internal Entry Anti-Blowout Stem
- Adjustable Vee Style Stem Packing
- In-Line Maintainable
- Stainless Steel Cast Body and Ends
- Threaded to ANSI B2.1
- Meets WW-V-35 Design Specifications
- ISO 5211 Direct Mounting Pad

### ACTUATOR FEATURES

- ISO 5211 Mounting Pattern
- Heavy Duty Gears
- Permanently Lubricated
- 2 SPDT Independently Adjustable Switches
- Thermal Overload Protection
- 6 Position Terminal Strip
- Wired for Light Indication

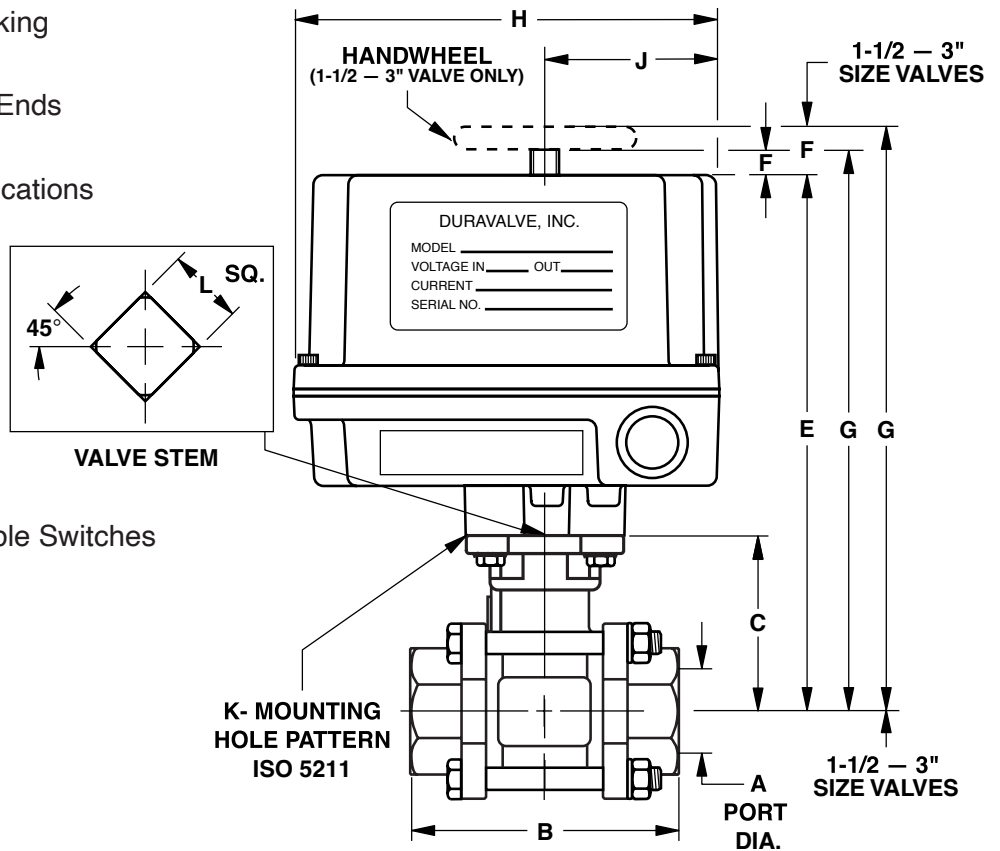

(Dimensions in inches)

Valve Size	Assembly No w/Thread. Ends	Assembly No. w/SW Ends	Actuator Model No.	A	B	C	E	F	G	H	J	K	L
1/2	EA3102	NA	DR-2B	.59	2.96	1.50	6.40	.38	6.78	5.63	2.31	F03	.35
3/4	EA3103	NA	DR-2B	.79	3.15	1.85	6.64	.38	7.02	5.63	2.31	F04	.35
1	EA3104	NA	DR-2B	.98	3.54	2.36	6.98	.38	7.36	5.63	2.31	F04	.43
1-1/4	EA3105	NA	DSR-5	1.26	4.33	2.47	7.78	.50	8.28	6.88	4.45	F05	.43
1-1/2	EA3106	NA	DSR-5	1.50	4.72	3.11	9.79	.50	11.04	6.88	4.62	F05	.55
2	EA3107	NA	DSX-5	1.97	5.51	3.46	10.10	1.75	11.35	6.88	4.62	F07	.55
2-1/2	EA3108	NA	DML-15	2.52	7.28	4.29	11.02	1.75	12.27	7.00	4.62	F07	.67
3	EA7319	NA	DMH-30	3.54	8.07	4.57	11.37	1.75	12.62	10.00	4.62	F10	.67

