

# DURAVALVE MODEL V3000 BALL VALVE

## 2-PIECE FULL PORT BRASS 600 WOG



### FEATURES AND SPECIFICATIONS

- 1/2" to 2" Sizes
- Triple Stem Seal Design
- NPT Threaded Ends to ANSI B2.1
- Internal Entry Blow-Out Proof Stem
- ISO 5211 Actuator Mounting Pad
- Pressure Rating: 600 PSI Maximum
- Temperature Range: -20° F – 400° F
- Meets WW-V-35 Design Specifications

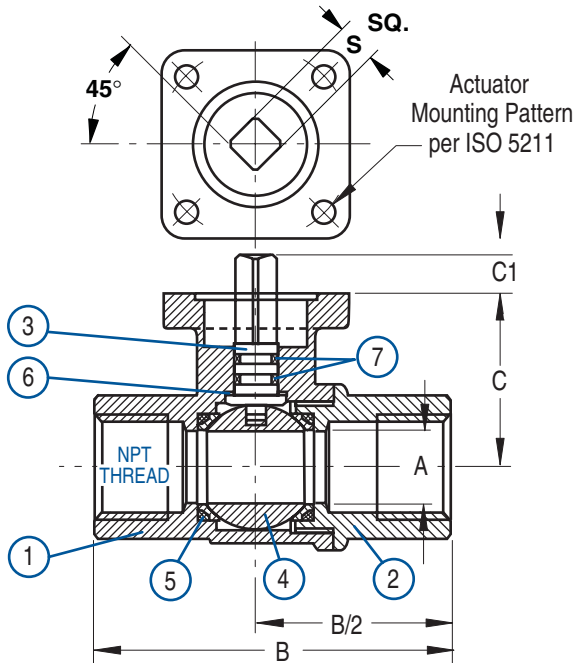

### MATERIALS OF CONSTRUCTION

Item	Description	Material	Qty.
1.	Body	Forged Brass	1
2.	Body End	Forged Brass	1
3.	Stem*	Brass w/ Chrome Plate	1
4.	Ball*	Brass w/ Chrome Plate	1
5.	Seats	RTFE	2
6.	Thrust Washer	RTFE	1
7.	Stem Seal	Viton O-Rings	2

### DIMENSIONS IN INCHES

Valve Size	Part Number*		A	B	C	C1	ISO 5211 Mtg. Pattern	S mm.	Cv	Torque In. - Lb.
	Brass Trim	SS Trim								
1/2	80500C	80514C	.59	2.54	1.38	.28	F03	9	21	30
3/4	80500D	80514D	.78	2.94	1.78	.28	F04	9 or 11	33	45
1	80500E	80514E	.98	3.50	1.94	.41	F04	11	53	70
1-1/4	80500F	80514F	1.25	4.00	2.50	.55	F05	14	90	120
1-1/2	80500G	80514G	1.57	4.46	2.75	.55	F05	14	149	190
2	80500H	80514H	1.96	5.12	3.31	.55	F05	14	215	300

\*Series 80500 has brass ball and stem. Series 80514 has stainless steel ball and stem.

### PRESSURE/TEMPERATURE CURVE

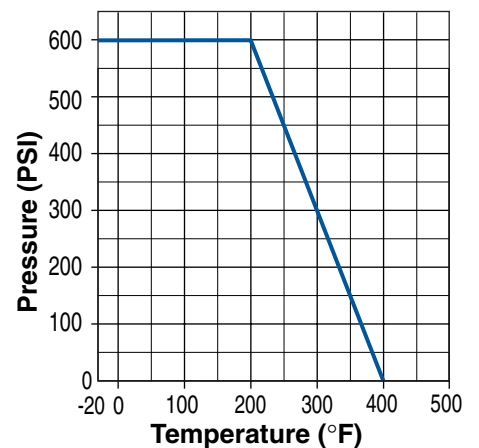

847-616-0430

• 800-776-1260

• FAX 847-616-0432

• www.duravalve.com