

DURAVALVE MODEL DM 340 BALL VALVE

with Electric Actuator

VALVE FEATURES

- Internal Entry Anti-Blowout Stem
- Adjustable Vee Style Stem Packing
- In-Line Maintainable
- Stainless Steel Cast Body and Ends
- Threaded to ANSI B2.1 or Socketweld Ends
- Meets WW-V-35 Design Specifications
- ISO 5211 Direct Mounting Pad

ACTUATOR FEATURES

- ISO 5211 Mounting Pattern
- Heavy Duty Gears
- Permanently Lubricated
- 2 SPDT Independently Adjustable Switches
- Thermal Overload Protection
- 6 Position Terminal Strip
- Wired for Light Indication

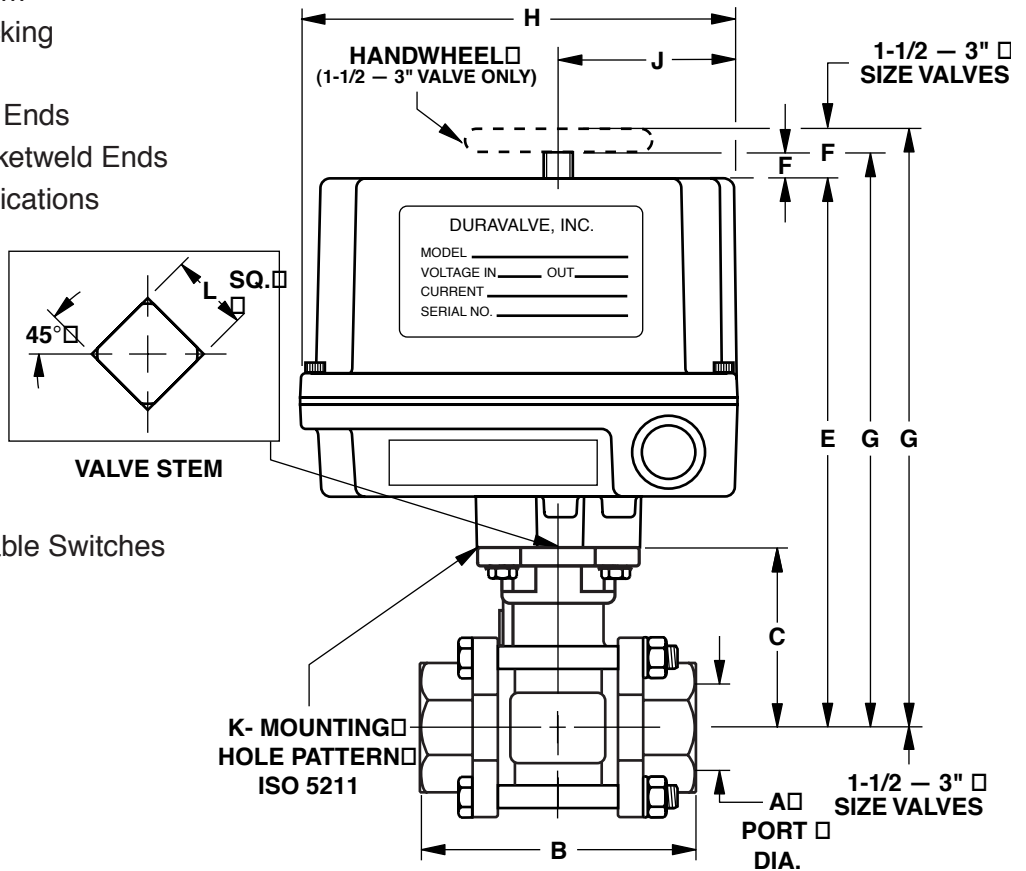

(Dimensions in inches)

Valve Size	Assembly No w/Thread. Ends	Assembly No. w/SW Ends	Actuator Model No.	A	B	C	E	F	G	H	J	K	L
1/4	EA7000	EA7100	DR-2A	.45	2.50	1.65	6.40	.38	6.78	5.63	2.31	F03	.35
3/8	EA7001	EA7101	DR-2A	.50	2.50	1.65	6.40	.38	6.78	5.63	2.31	F03	.35
1/2	EA7002	EA7102	DR-2A	.59	2.62	1.65	6.40	.38	6.78	5.63	2.31	F03	.35
3/4	EA7003	EA7103	DR-2A	.79	3.00	1.89	6.64	.38	7.02	5.63	2.31	F03	.35
1	EA7004	EA7104	DR-2B	.99	3.38	2.23	6.98	.38	7.36	5.63	2.31	F04	.43
1-1/4	EA7005	EA7105	DSX-5	1.26	4.06	2.40	7.78	.50	8.28	6.88	4.45	F05	.43
1-1/2	EA7006	EA7106	DSH-10	1.50	4.68	3.05	9.79	1.25	11.04	7.00	4.62	F07	.55
2	EA7007	EA7107	DMR-15	1.97	5.17	3.36	10.10	1.25	11.35	7.00	4.62	F07	.55
2-1/2	EA7008	EA7108	DML-15	2.56	6.46	4.28	11.02	1.25	12.27	7.00	4.62	F07	.67
3	EA7009	EA7109	DMH-30	3.15	7.19	4.63	11.37	1.25	12.62	7.00	4.62	F07	.67

