

# DURAVALVE MODEL D220 BALL VALVE with Electric Actuator

## VALVE FEATURES

- Internal Entry Anti-Blowout Stem
- Adjustable Vee Style Stem Packing
- Stainless Steel Cast Body and End
- Threaded Ends to ANSI B2.1
- Meets WW-V-35 Design Specifications

## ACTUATOR FEATURES

- ISO 5211 Mounting Pattern
- Heavy Duty Gears
- Permanently Lubricated
- 2 SPDT Independently Adjustable Switches
- Thermal Overload Protection
- 6 Position Terminal Strip
- Wired for Light Indication

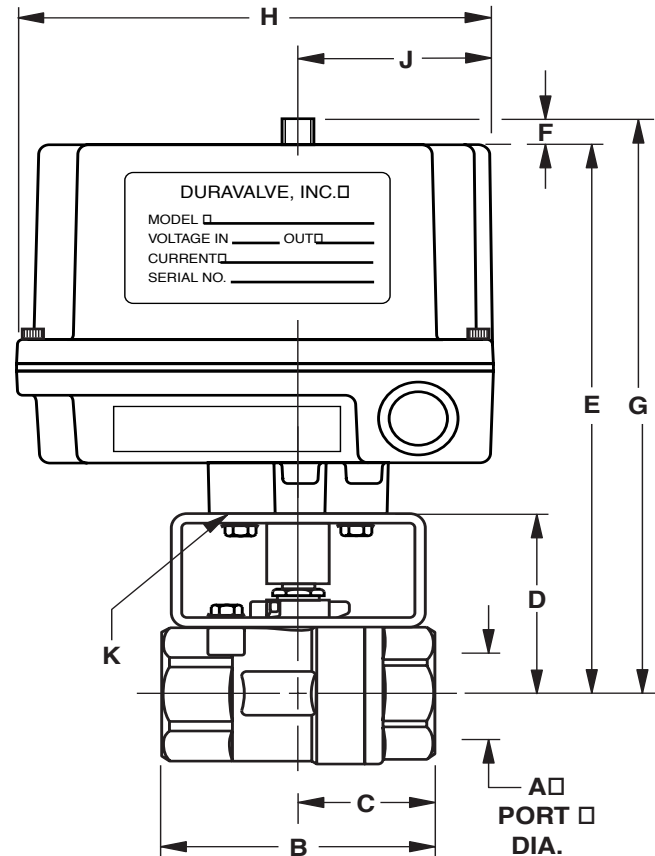

(Dimensions in inches)

Valve Size	Assembly No	Actuator Model No.	A	B	C	D	E	F	G	H	J	K
1/4	EA5000	DR-2A	.38	2	1	2-1/16	6-13/16	3/8	7-3/16	5-9/16	2-5/16	F03
3/8	EA5001	DR-2A	.46	2	1	2-1/16	6-13/16	3/8	7-3/16	5-9/16	2-5/16	F03
1/2	EA5002	DR-2A	.50	2-3/8	1-3/16	2-1/8	6-7/8	3/8	7-1/4	5-9/16	2-5/16	F03
3/4	EA5003	DR-2B	.59	2-3/4	1-3/8	2-11/16	7-7/16	3/8	7-13/16	5-9/16	2-5/16	F04
1	EA5004	DSR-5	.79	3-1/4	1-5/8	2-13/16	8-3/16	1/2	8-11/16	6-11/16	4-7/16	F05
1-1/4	EA5005	DSR-5	1.00	3-5/8	1-13/16	2-7/8	8-1/4	1/2	8-3/4	6-11/16	4-7/16	F05
1-1/2	EA5006	DSX-5	1.26	4-1/8	2-1/16	3-3/16	8-9/16	1/2	9-1/16	6-11/16	4-7/16	F05
2	EA5007	DSX-5	1.50	4-5/8	2-5/16	3-1/2	8-7/8	1/2	9-3/8	6-11/16	4-7/16	F05

