

# DURAVALVE MODEL D210 BALL VALVE

## 2-PIECE FULL PORT 316 STAINLESS STEEL 1000 PSI



### FEATURES AND SPECIFICATIONS

- 1/4" to 2" Sizes
- Adjustable Vee Style Stem Packing
- NTP Threaded Ends to ANSI B2.1
- Internal Entry Blow-Out Proof Stem
- Pressure Rating: 1000 PSI Maximum
- Temperature Range: -20° F – 450° F
- Meets WW-V-35 Design Specifications

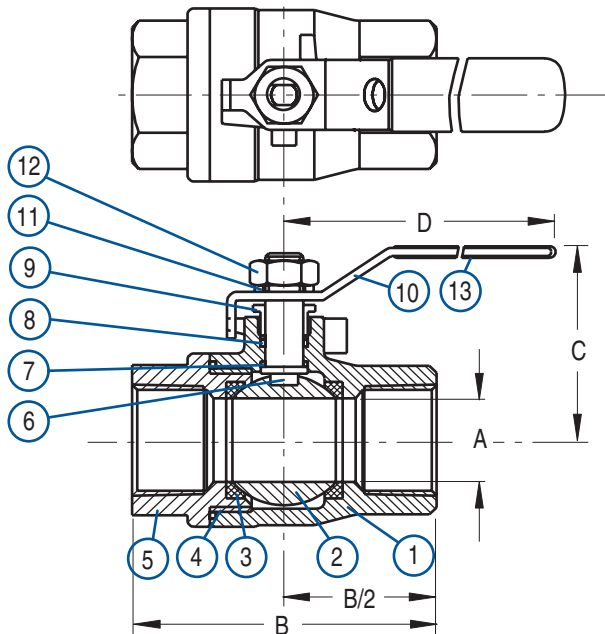

### MATERIALS OF CONSTRUCTION

Item	Description	Material	Qty.
1.	Body	CF8M	1
2.	Ball	CF8M	1
3.	Seat	RTFE	2
4.	End Gasket	PTFE	1
5.	End Cap	CF8M	1
6.	Stem	316 SS	1
7.	Thrust Washer	RTFE	1
8.	Stem Packing	PTFE	1
9.	Gland Nut	304 SS	1
10.	Handle	304 SS	1
11.	Washer	304 SS	1
12.	Nut	304 SS	1
13.	Handle Sleeve	Vinyl	1

### DIMENSIONS IN INCHES

Valve Size	Part Number	A	B	C	D	Weight Lbs.	Cv	Torque In.-Lb.
1/4	20200A	.47	2.09	1.81	3.62	.46	7	40
3/8	20200B	.47	2.09	1.81	3.62	.46	9	40
1/2	20200C	.59	2.48	1.93	3.62	.68	11	60
3/4	20200D	.79	2.91	2.24	4.57	1.15	24	80
1	20200E	.98	3.39	2.60	5.63	1.85	45	120
1-1/4	20200F	1.26	3.90	2.80	5.63	2.82	90	240
1-1/2	20200G	1.50	4.25	3.19	6.97	4.19	125	420
2	20200H	1.97	5.20	3.50	6.97	6.66	190	560

### PRESSURE/TEMPERATURE CURVE

