

DURAVALVE MODEL V3000 BALL VALVE

with Electric Actuator

VALVE FEATURES

- ISO 5211 Mounting
- Internal Entry Anti-Blowout Stem
- Triple Stem Seal Design
- Meets WW-V-35 Design Specifications
- Forged Brass Body and End
- Full Port Design
- Threaded Ends to ANSI B2.1
- Optional Stainless Steel Ball and Stem

ACTUATOR FEATURES

- ISO 5211 Mounting
- Heavy Duty Gears
- Permanently Lubricated
- 2 SPDT Independently Adjustable Switches
- Thermal Overload Protection
- 6 Position Terminal Strip
- Wired for Light Indication

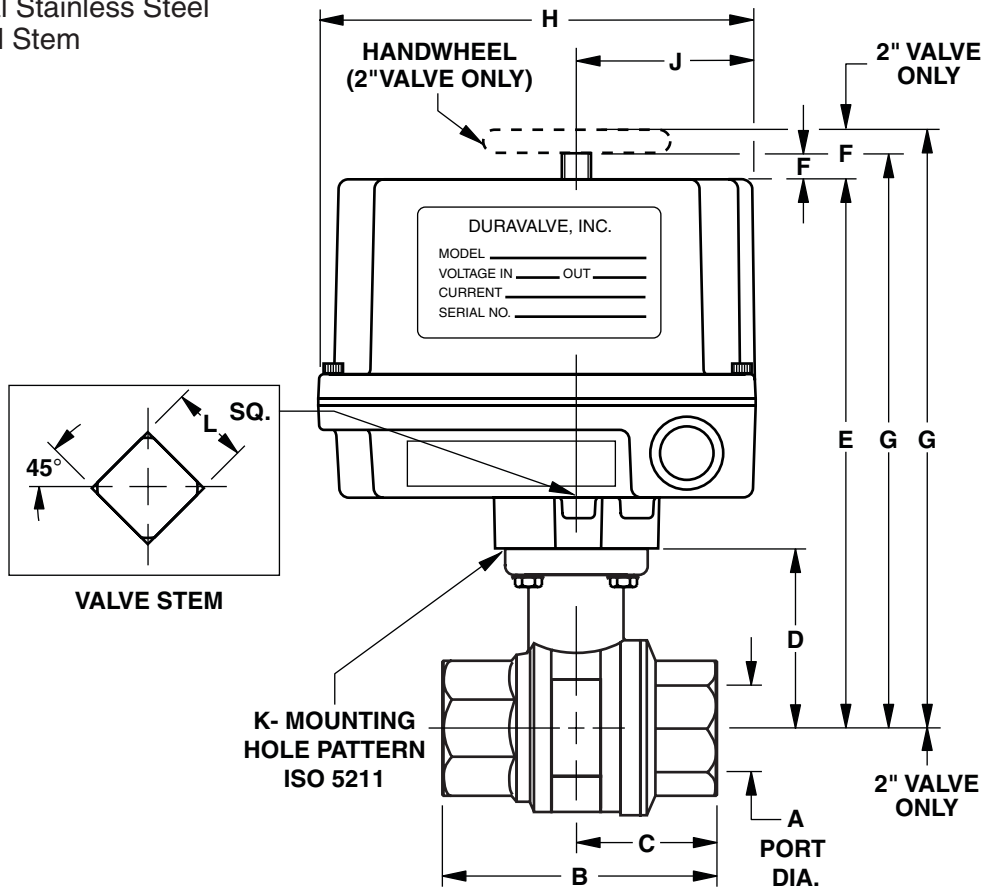

(Dimensions in inches)

Valve Size	Assembly No w/Brass Trim	Assembly No. w/SS Trim	Actuator Model No.	A	B	C	D	E	F	G	H	J	K	mm. L
1/2	EA1000	EA2000	DR-2A	.59	2.54	1.27	1.38	6.09	.38	6.46	5.63	2.31	F03	9
3/4	EA1001	EA2001	DR-2B	.78	2.94	1.47	1.78	6.52	.38	6.90	5.63	2.31	F04	9 or 11
1	EA1002	EA2002	DR-2B	.98	3.50	1.75	1.94	6.71	.38	7.09	6.63	2.31	F04	11
1-1/4	EA1003	EA2003	DSR-5	1.25	4.00	2.00	2.50	8.23	.50	8.73	6.88	4.44	F05	14
1-1/2	EA1004B	EA2004B	DSR-5	1.57	4.46	2.23	2.75	8.47	.50	8.97	6.88	4.44	F05	14
2	EA1005C	EA2005C	DSx-5	1.96	5.12	2.56	3.31	8.63	.50	10.38	6.88	4.63	F05	14

