

DURAVALVE MODEL DM 240 BALL VALVE

with DurAir II Pneumatic Actuator

VALVE FEATURES

- Internal Entry Anti-Blowout Stem
- Adjustable Vee Style Stem Packing
- Stainless Steel Cast Body and End
- Threaded Ends to ANSI B16.11
- Meets WW-V-35 Design Specifications
- ISO 5211 Direct Mounting Pad

ACTUATOR FEATURES

- ISO 5211 Mounting Pattern
- Aluminum Body
- Rack & Pinion Double Acting and Spring Return
- Low Friction Bearings and High Cycle Life
- Optional ENP (electroless nickel plated finish)

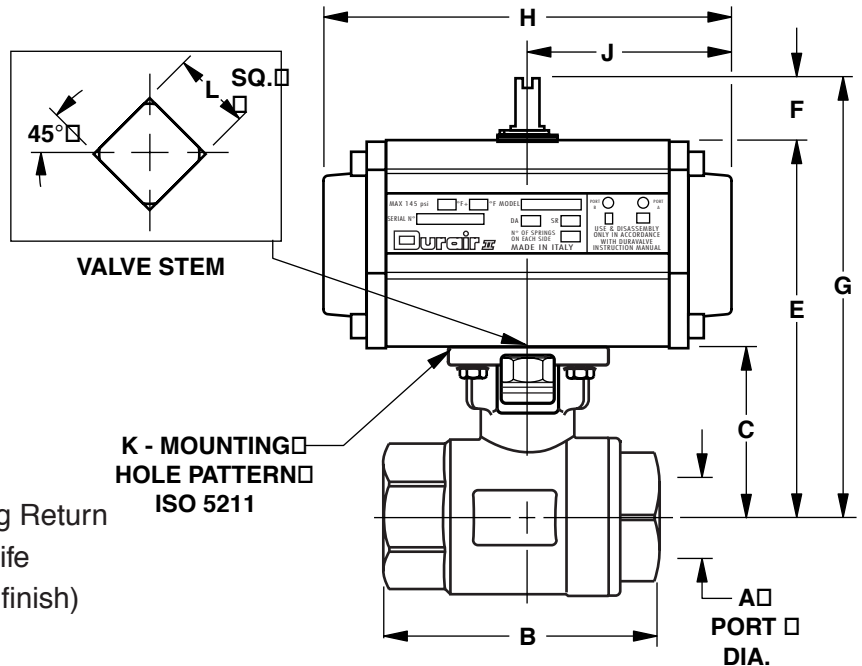

DOUBLE ACTING (Dimensions in inches)

Valve Size	Assembly No	Actuator Model No.	A	B	C	E	F	G	H	J	K	L
1/2	AS7202	AP032	.59	2.56	1.52	3.29	.79	4.08	4.61	2.31	F03	.35
3/4	AS7203	AP050	.79	2.93	1.82	4.45	.79	5.24	5.43	2.72	F03	.35
1	AS7204	AP050	.99	3.46	2.23	4.86	.79	5.65	5.43	2.72	F04	.43
1-1/4	AS7205	AP063	1.26	4.02	2.40	5.67	.79	6.46	6.12	3.06	F04	.43
1-1/2	AS7206	AP075	1.49	4.33	3.00	6.94	.79	7.73	8.27	4.14	F07	.55
2	AS7207	AP075	1.93	4.93	3.31	7.25	.79	8.04	8.27	4.14	F07	.55
2-1/2	AS7208	AP100	2.56	6.32	4.28	9.20	.79	9.99	11.04	5.52	F10	.67
3	AS7209	AP115	3.15	7.00	4.62	10.22	1.18	11.40	12.20	6.10	F10	.67

SPRING RETURN (Dimensions in inches)

Valve Size	Assembly No	Actuator Model No.	A	B	C	E	F	G	H	J	K	L
1/2	AS7212	AP050	.59	2.56	1.52	4.15	.79	4.94	5.43	2.72	F03	.35
3/4	AS7213	AP063	.79	2.93	1.82	5.09	.79	5.88	6.12	3.06	F04	.35
1	AS7214	AP063	.99	3.46	2.23	5.50	.79	6.29	6.12	3.06	F04	.43
1-1/4	AS7215	AP075	1.26	4.02	2.40	6.34	.79	7.13	8.27	4.14	F05	.43
1-1/2	AS7216	AP085	1.49	4.33	3.00	7.33	.79	8.12	8.97	4.49	F07	.55
2	AS7217	AP100	1.93	4.93	3.31	8.23	.79	9.02	11.04	5.52	F07	.55
2-1/2	AS7218	AP115	2.56	6.32	4.28	9.88	1.18	11.06	12.20	6.10	F10	.67
3	AS7219	AP145	3.15	7.00	4.62	11.51	1.18	12.69	15.35	7.68	F10	.67

