

DURAVALVE MODEL DM 240 BALL VALVE

2-PIECE FULL PORT STAINLESS STEEL



VALVE FEATURES

- 2-Piece Body, Full Port Design
- 1/4" to 3" Sizes
- Threaded Ends
- Body: CF8M, 316SS
- 316 Stainless Steel Ball and Stem
- RTFE Seats
- Pressure Rating: 1/4" – 1" 1500 PSI
1-1/4" and 1-1/2" 1250 PSI
2" 1000 PSI
2-1/2" and 3" 800 PSI
- Temperature Range: -20° F – 450° F

DESIGN ADVANTAGES

- ISO 5211 Direct Mounting Pad – provides for precise shaft alignment and eliminates the need for brackets and couplings
- 2-Piece Investment Cast Body Construction
- Improved Seat Material – extends cycle life and reduces torque
- Blowout Proof Stem
- Anti-Static Device – standard in all sizes
- Locking Device for valves with handle
- Adjustable “Live Loaded” Stem Seal

STEM SEAL DESIGN

DuraValve's triple stem seal design provides for an extended valve cycle life. The primary seal is a tapered seal ring that fits firmly on a tapered portion of the stem shoulder. The secondary (back-up) seal is provided by an O-ring and a set of Vee packing rings, energized by bellville washers. This design adjusts packing compression to compensate for wear, pressure or temperature fluctuations.

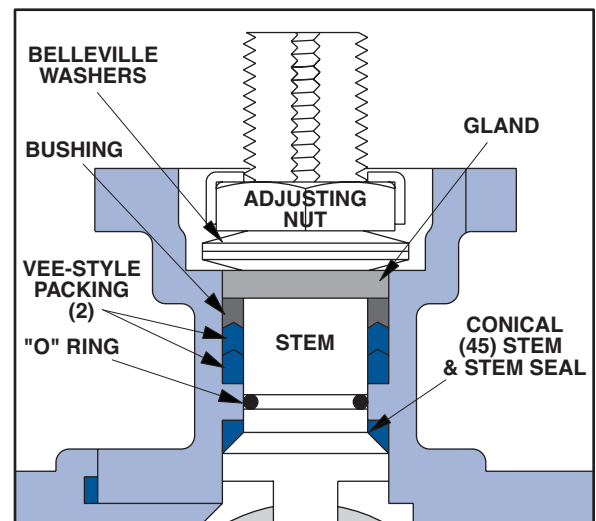

DURAVALVE MODEL DM 240 BALL VALVE

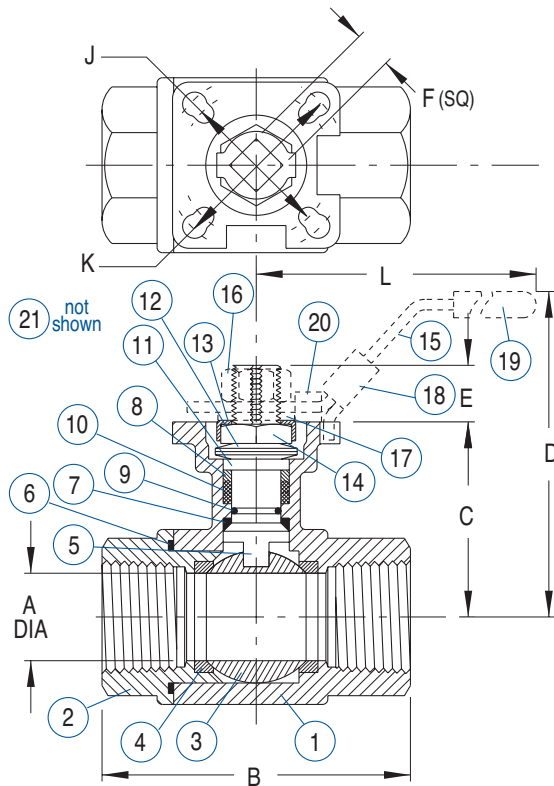

PRESSURE/TEMPERATURE CURVE

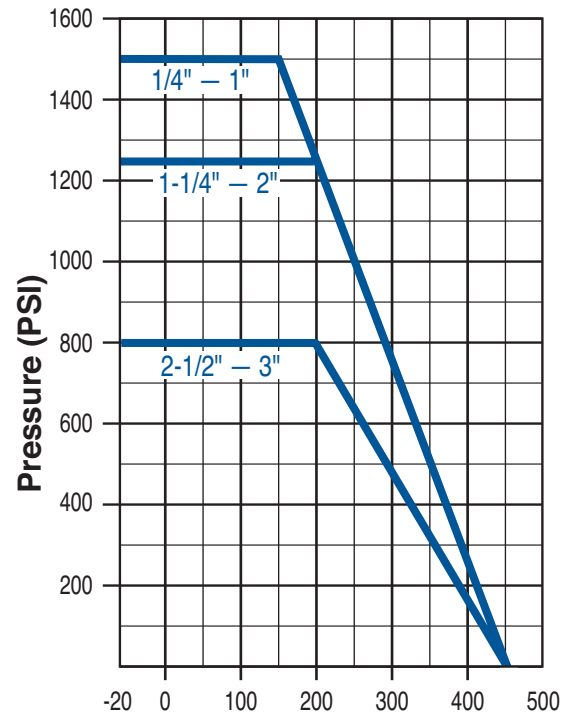

DIMENSIONS IN INCHES

Valve Size	Part No.	A	B	C	D	E	F	J	K	L	Weight Lbs.	Cv	Torque In-#	ISO5211
1/4"	20400AC	0.45	2.56	1.52	2.86	0.30	0.35	1.42	1.65	5.50	1.17	15	50	F03/F04
3/8"	20400BC	0.49	2.56	1.52	2.86	0.30	0.35	1.42	1.65	5.50	1.121	15	50	F03/F04
1/2"	20400CC	0.59	2.56	1.52	2.86	0.30	0.35	1.42	1.65	5.50	1.01	15	50	F03/F04
3/4"	20400DC	0.79	2.93	1.82	3.20	0.30	0.35	1.42	1.65	5.50	1.32	35	70	F03/F04
1"	20400EC	0.99	3.46	2.23	3.75	0.45	0.43	1.65	1.97	6.50	2.40	60	100	F04/F05
1-1/4"	20400FC	1.26	4.02	2.40	3.92	0.45	0.43	1.65	1.97	6.50	3.30	105	220	F04/F05
1-1/2"	20400GC	1.49	4.33	3.00	4.36	0.57	0.55	1.97	2.76	8.50	5.62	138	390	F05/F07
2"	20400HC	1.93	4.93	3.31	4.67	0.57	0.55	1.97	2.76	8.50	7.93	270	480	F05/F07
2-1/2"	20400JC	2.56	6.32	4.28	6.54	0.73	0.67	2.76	4.02	10.38	16.37	380	1050	F07/F10
3"	20400KC	3.15	7.00	4.62	6.89	0.73	0.67	2.76	4.02	10.38	22.81	580	1500	F07/F10

MATERIALS OF CONSTRUCTION

STANDARDS

ANSI/ASME B16.11
 ISO 5211
 MSS SP25, SP72

Note: The right is reserved to change or modify product design or construction without prior notice and without incurring any obligation to make such changes or modifications on products previously or subsequently sold.

Item	Description	Material	Quantity	Item	Description	Material	Quantity
1.	Body	CF8M (316SS)	1	12.	Belleville Washer	301 SS	2
2.	Body End	CF8M (316SS)	1	13.	Lock Saddle	304 SS	1
3.	Ball	316 SS	1	14.	Adjusting Nut	304 SS	1
4.	Seat	RTFE	2	15.	Handle*	304 SS	1
5.	Stem	316 SS	1	16.	Handle Nut*	304 SS	1
6.	Body Seal	PTFE	1	17.	Stem Washer*	304 SS	1
7.	Thrust Washer	RTFE	1	18.	Locking Device*	304 SS	1
8.	Bushing	RTFE	1	19.	Handle Sleeve*	Vinyl	1
9.	O-ring	Viton®	1	20.	Stop Pin*	304 SS	1
10.	Packing	PTFE	2	21.	Anti-Static Device	304 SS	1
11.	Gland	304 SS	1				

* Handle and associated components optional.



847-437-7000 • 800-776-1260 • FAX 847-437-7005 • www.duravalve.com

DM24012-16