

DURAVALVE MODEL DF150 BALL VALVE

2-PIECE FULL PORT STAINLESS STEEL FLANGED END

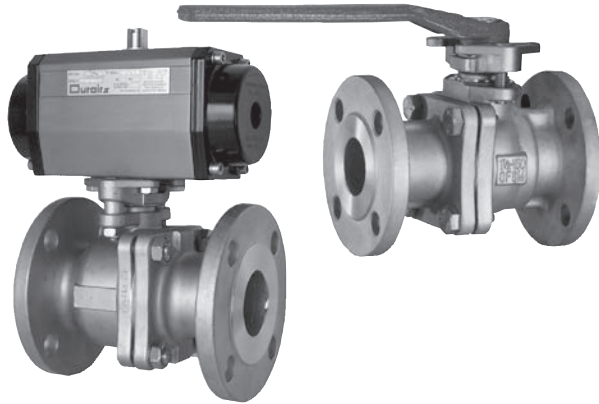

FEATURES AND SPECIFICATIONS

- 1/2" to 6" Sizes
- Adjustable Vee Style Stem Packing
- Internal Entry Blow-Out Proof Stem
- Solid Ball
- ISO 5211 Actuator Mounting Pad
- Body and Body End: ASTM A351-CF8M
- End to End: ANSI B16.10 CL.150
- Flange: ANSI B16.5 CL.150

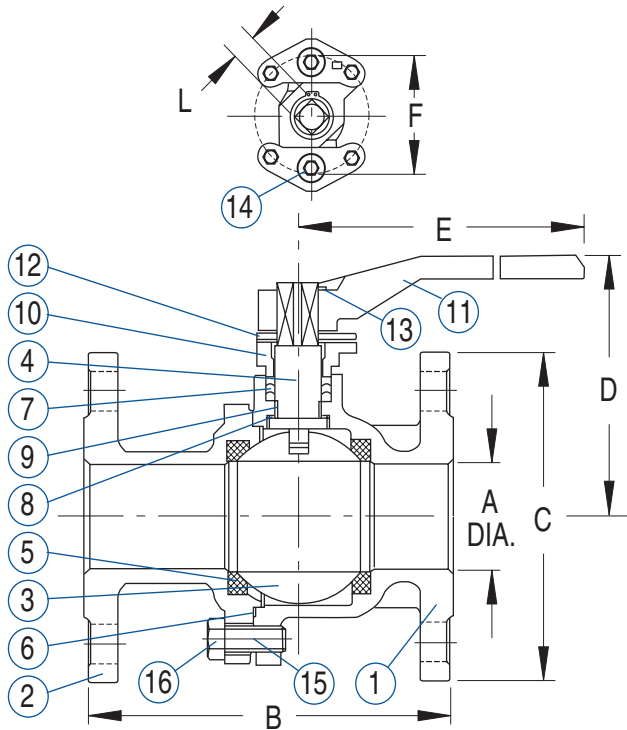

PRESSURE/TEMPERATURE CURVE

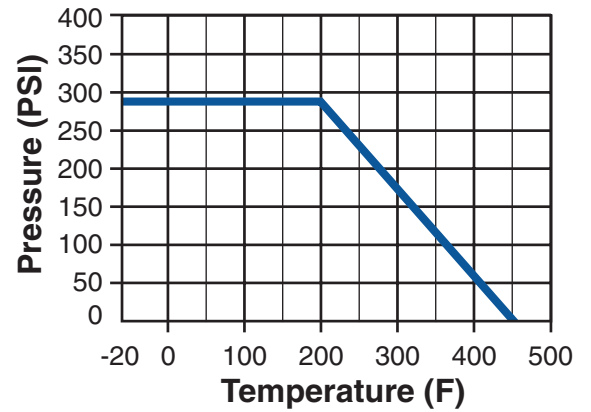

MATERIALS OF CONSTRUCTION

| Item | Description | Material | Qty. |
|------|---------------|----------------|------|
| 1. | Body | ASTM A351 CF8M | 1 |
| 2. | Cap | ASTM A351 CF8M | 1 |
| 3. | Ball | ASTM A351 CF8M | 2 |
| 4. | Stem | ASTM A276 316 | 1 |
| 5. | Seats | PTFE | 1 |
| 6. | Gasket | PTFE | 1 |
| 7. | Stem Packing | PTFE | 1 |
| 8. | Thrust washer | PTFE | 1 |
| 9. | Bearing | PTFE | 1 |
| 10. | Gland Flange | ASTM A351 CF8M | 1 |
| 11. | Handle | FCD45 | 1 |
| 12. | Stop Plate | 304 SS | 1 |
| 13. | Snap Ring | 304 SS | 1 |
| 14. | Gland Bolt | ASTM A193-B8 | 1 |
| 15. | Bolt | ASTM A193-B8 | 1 |
| 16. | Nut | ASTM A194-8 | 1 |

DIMENSIONS IN INCHES

| Valve Size | Part Number | A | B | C | D | E | F | L SQ (mm.) | Wt. Lbs. | Cv | Max. Torque In-Lb. | Mounting Pattern ISO 5211 |
|------------|-------------|------|-------|-------|-------|-------|------|------------|----------|------|--------------------|---------------------------|
| 1/2 | 40200C | .59 | 4.25 | 3.50 | 3.23 | 4.92 | 1.65 | 9 | 4 | 20 | 50 | F04 |
| 3/4 | 40200D | .79 | 4.63 | 3.88 | 3.35 | 4.92 | 1.65 | 9 | 4.7 | 45 | 70 | F04 |
| 1 | 40200E | .98 | 5.00 | 4.25 | 3.70 | 5.71 | 1.97 | 11 | 6.8 | 80 | 100 | F05 |
| 1-1/2 | 40200G | 1.57 | 6.50 | 5.00 | 4.53 | 9.06 | 2.76 | 17 | 14 | 250 | 390 | F07 |
| 2 | 40200H | 1.97 | 7.00 | 6.00 | 4.72 | 9.06 | 2.76 | 17 | 20 | 500 | 480 | F07 |
| 3 | 40200K | 3.15 | 8.00 | 7.50 | 6.50 | 15.75 | 4.02 | 22 | 44 | 1250 | 1500 | F10 |
| 4 | 40200L | 3.94 | 9.00 | 9.00 | 7.87 | 18.11 | 4.02 | 27 | 71 | 2500 | 2500 | F10 |
| 6 | 40200M | 5.91 | 15.50 | 11.00 | 10.04 | 31.50 | 4.92 | 27 | 199 | 5400 | 4400 | F12 |

