

# DURAVALVE MODEL DI 10 BALL VALVE

## I-PIECE REDUCED PORT 316 STAINLESS STEEL 800 PSI



### FEATURES AND SPECIFICATIONS

- 1/4" to 2" Sizes
- NTP Threaded Ends to ANSI B2.1
- Internal Entry Blow-Out Proof Stem
- Pressure Rating: 800 PSI Maximum
- Temperature Range: -20° F – 450° F
- Meets WW-V-35 Design Specifications

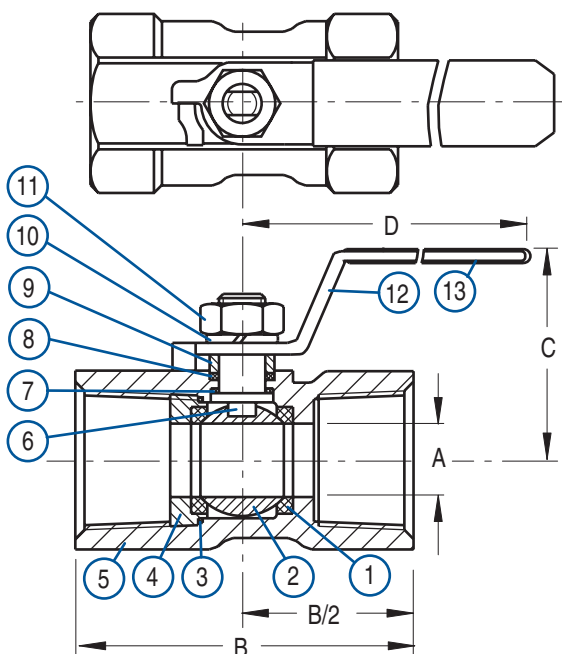

### MATERIALS OF CONSTRUCTION

Item	Description	Material	Qty.
1.	Seat	RTFE	2
2.	Ball	316 SS	1
3.	Insert Seal	PTFE	1
4.	Insert	316 SS	1
5.	Body	316 SS	1
6.	Stem	316 SS	1
7.	Thrust Washer	RTFE	1
8.	Stem Packing	RTFE	1
9.	Washer	304 SS	1
10.	Washer	304 SS	1
11.	Nut	304 SS	1
12.	Handle	304 SS	1
13.	Sleeve	Vinyl	1

### DIMENSIONS IN INCHES

Valve Size	Part Number	A	B	C	D	Weight Lbs.	Cv	Torque In.-Lb.
1/4	10100A	.20	1.54	1.38	2.52	.15	4	12
3/8	10100B	.28	1.73	1.46	2.76	.22	4	12
1/2	10100C	.36	2.24	1.73	3.54	.35	4.5	16
3/4	10100D	.49	2.28	1.85	3.54	.55	9	28
1	10100E	.59	2.80	1.97	4.06	.94	16	60
1-1/4	10100F	.79	3.07	2.24	4.06	1.54	24	86
1-1/2	10100G	.96	3.27	2.72	5.00	1.83	37	110
2	10100H	1.26	3.94	2.95	5.00	3.30	68	150

### PRESSURE/TEMPERATURE CURVE

