

DURAVALVE MODEL DFI50 BALL VALVE

with Electric Actuator

VALVE FEATURES

- 2-Piece Full Port Construction
- Internal Entry Anti-Blowout Stem
- Adjustable Vee Style Stem Packing
- Anti Static Device
- Stainless Steel Cast Body and Ends
- Solid Ball
- Flanged End To End ANSI B16.10 CL. 150
- Flange Ends Conform to ANSI B16.5
- ISO 5211 Actuator Mounting Pad

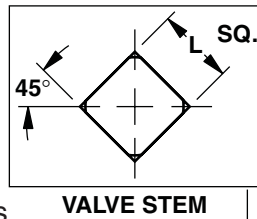

ACTUATOR FEATURES

- Heavy Duty Gears
- Permanently Lubricated
- 2 SPDT Independently Adjustable Switches
- Thermal Overload Protection
- 6 Position Terminal Strip
- Wired for Light Indication

K - VALVE MOUNTING HOLE PATTERN ISO 5211

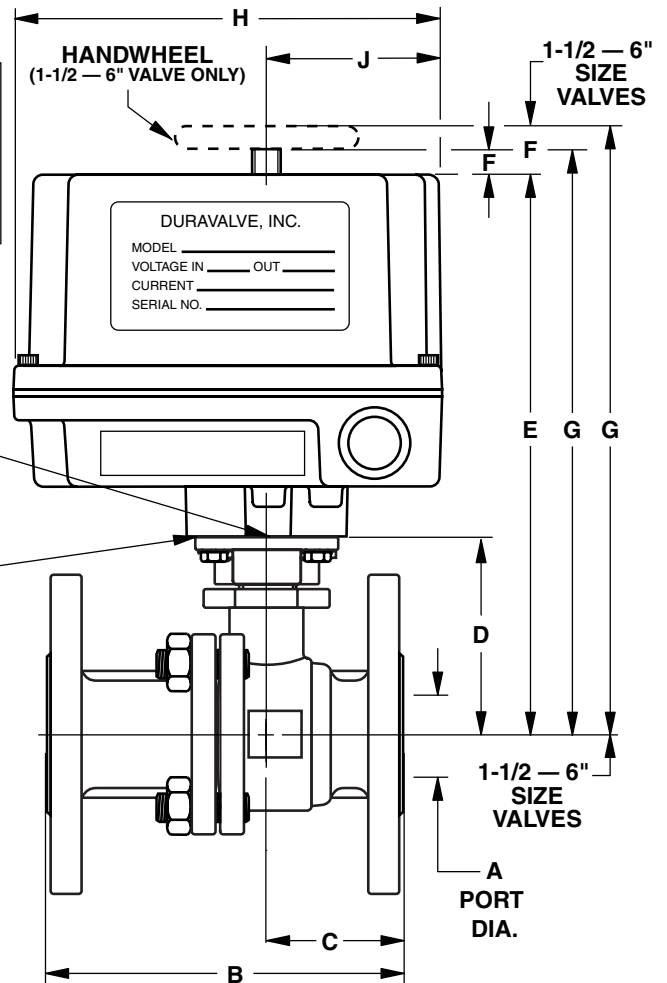

(Dimensions in inches)

Valve Size	Assembly No	Actuator Model No.	A	B	C	D	E	F	G	H	J	K*	mm. L
1/2	EA5302B	DR-2B	.59	4.25	1.75	2.06	6.76	.38	7.14	5.60	3.30	F04	9
3/4	EA5303B	DR-2B	.79	4.63	2.00	2.18	6.88	.38	7.26	5.60	3.30	F04	9
1	EA5304B	DR-5	.98	5.00	2.13	2.63	8.01	.50	8.51	6.88	4.45	F05	11
1-1/2	EA5305B	DSH-10	1.57	6.50	2.63	3.34	10.04	1.75	11.79	7.00	4.62	F07	17
2	EA5306B	DMR-15	1.97	7.00	2.87	3.75	10.45	1.75	12.20	7.00	4.62	F07	17
3	EA5307B	DP4-16	3.15	8.00	3.63	5.19	17.69	—	17.69	15.50	—	F10	22
4	EA5308B	DP4-16	3.94	9.00	4.50	6.19	18.69	—	18.69	15.50	—	F10	27
*6	EA5309B	DP5-22	5.91	15.50	6.00	8.25	20.75	—	20.75	15.50	—	F12	27

* 6" size with DP5-22 electric actuator utilizes 3" high bracket and coupling.

* K-ISO 5211

