

DURAVALVE MODEL D250 BALL VALVE

2-PIECE FULL PORT 316 STAINLESS STEEL



FEATURES AND SPECIFICATIONS

- 1/4" to 4" Sizes
- Adjustable Stem Packing
- End Connections: NPT Threads to ANSI B2.1
- Internal Entry Anti-Blowout Stem
- Latch-Lock Handle
- T-Handle Option for Sizes 1/4" – 3/4"
- Maximum Pressure: 1000 PSI Sizes 1/4" – 2"
600 PSI Sizes 2-1/2" – 4"
- Temperature Range: -20° F – 450° F
- Meets WW-V-35 Design Specifications

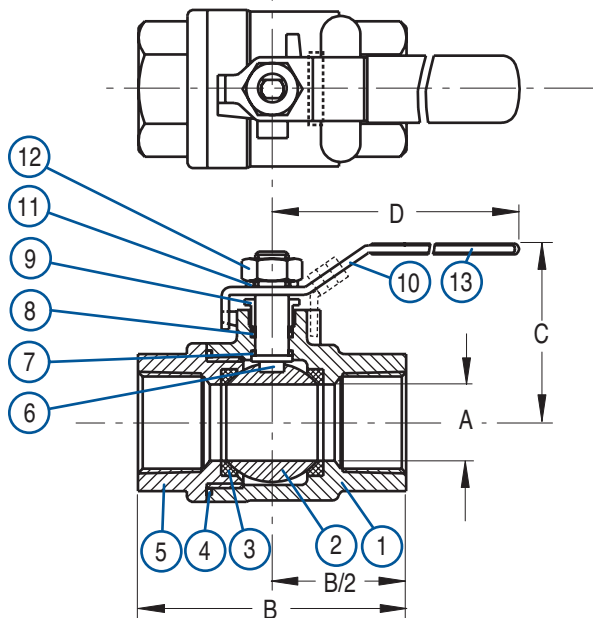

MATERIALS OF CONSTRUCTION

Item	Description	Material	Qty.
1.	Body	CF8M	1
2.	Ball	CF8M	1
3.	Seat	RTFE	2
4.	End Gasket	PTFE	1
5.	End Cap	CF8M	1
6.	Stem	316 SS	1
7.	Thrust Washer	RTFE	1
8.	Stem Packing	PTFE	1
9.	Gland Nut	304 SS	1
10.	Handle	304 SS	1
11.	Washer	304 SS	1
12.	Nut	304 SS	1
13.	Handle Sleeve	Vinyl	1

DIMENSIONS IN INCHES

Valve Size	Part Number	A	B	C	D	Weight Lbs.
1/4"	20500A	.46	1.97	1.90	3.75	.45
3/8"	20500B	.49	1.97	1.90	3.75	.45
1/2"	20500C	.59	2.28	2.05	4.10	.59
3/4"	20500D	.78	2.60	2.40	4.50	.92
1"	20500E	1.00	3.15	2.56	5.50	1.40
1-1/4"	20500F	1.26	3.62	3.10	5.90	2.30
1-1/2"	20500G	1.50	4.13	3.28	6.50	3.30
2"	20500H	2.00	4.92	3.80	7.50	5.40
2-1/2"	20500J	2.52	6.13	5.08	9.60	11.50
3"	20500K	3.00	7.20	5.43	9.60	18.60
4"	20500L	3.70	9.45	6.90	12.50	39.60

PRESSURE/TEMPERATURE CURVE

